

NOTES:

1. 3D DATABASE FEATURES TAKE PRECEDENCE OVER 2D DRAWINGS. REFER TO 3D DATABASE FILE (SEE MODEL NAME AND REVISION IN TITLE BLOCK).
2. ALL DIMENSIONS IN INCHES.
3. DIMENSIONS MARKED WITH \varnothing ARE SPC PROCESS CONTROL DIMENSIONS.
- FOR EXTERNAL DIMENSIONS, USE LARGEST OVERALL SIZE.
- FOR INTERNAL DIMENSIONS, USE SMALLEST OPENING.
4. UNLESS OTHERWISE STATED, THE ARTICLE SPECIFIED SHALL BE RoHS 2 COMPLIANT PER EU DIRECTIVE 2011/65/EU.

REVISION HISTORY			
DATE	REV	ECO #	COMMENT
01/30/18	@B	N/A	REVISED OVERLAY P/N

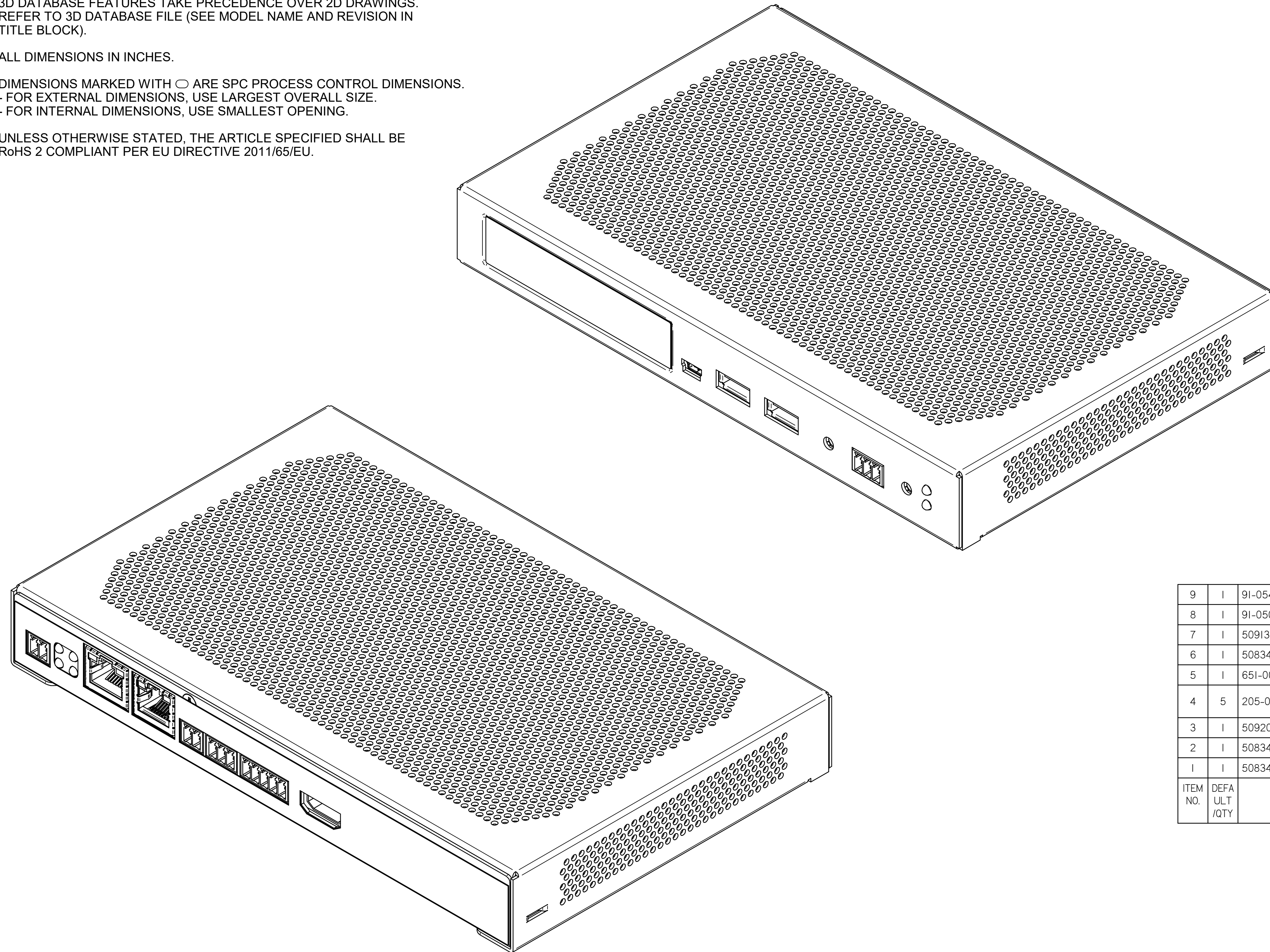

9	I	91-0540	LABEL_PCB	
8	I	91-0500-02	LABEL_UNIT	
7	I	5091377-01	OVERLAY,BACK,N2424A	
6	I	5083411	COFAN HEATSINK	
5	I	651-0006	LABEL_FRONT	
4	5	205-0008	Black Oxide SS Flat Head Phil Machine Screw 4-40 Thrd, 3/8" Length	
3	I	5092083-00	N2424A PCB	
2	I	5083414	ENCL_BASE,SVSIN2400 Series	
1	I	5083413	ENCL_LID,SVSIN2400 Series	
ITEM NO.	DEFA ULT /QTY	PART NUMBER	DESCRIPTION	NOTES

ITEM:	PART NO.	DESCRIPTION
TOLERANCE (EXCEPT AS NOTED)		SVSI
2 PLACES DECIMALS	3 PLACES DECIMALS	
HOLES	ANGLES	
MTL:		PRODUCT
N/A		N2424A-SA
FINISH:		DRN
N/A		END
NEXT ASSY		ENG G. WIRTH
SCALE		CHK
NTS	D	ENG
TITLE:		TITLE
DWG NO.		DWG,ASY,FGN2424A-SA
SHEET 1 OF 4		5092084-00
FILE NO.		TSK1410

REVISION HISTORY			
DATE	REV	ECO #	COMMENT
01/30/18	@B	N/A	REVISED OVERLAY P/N

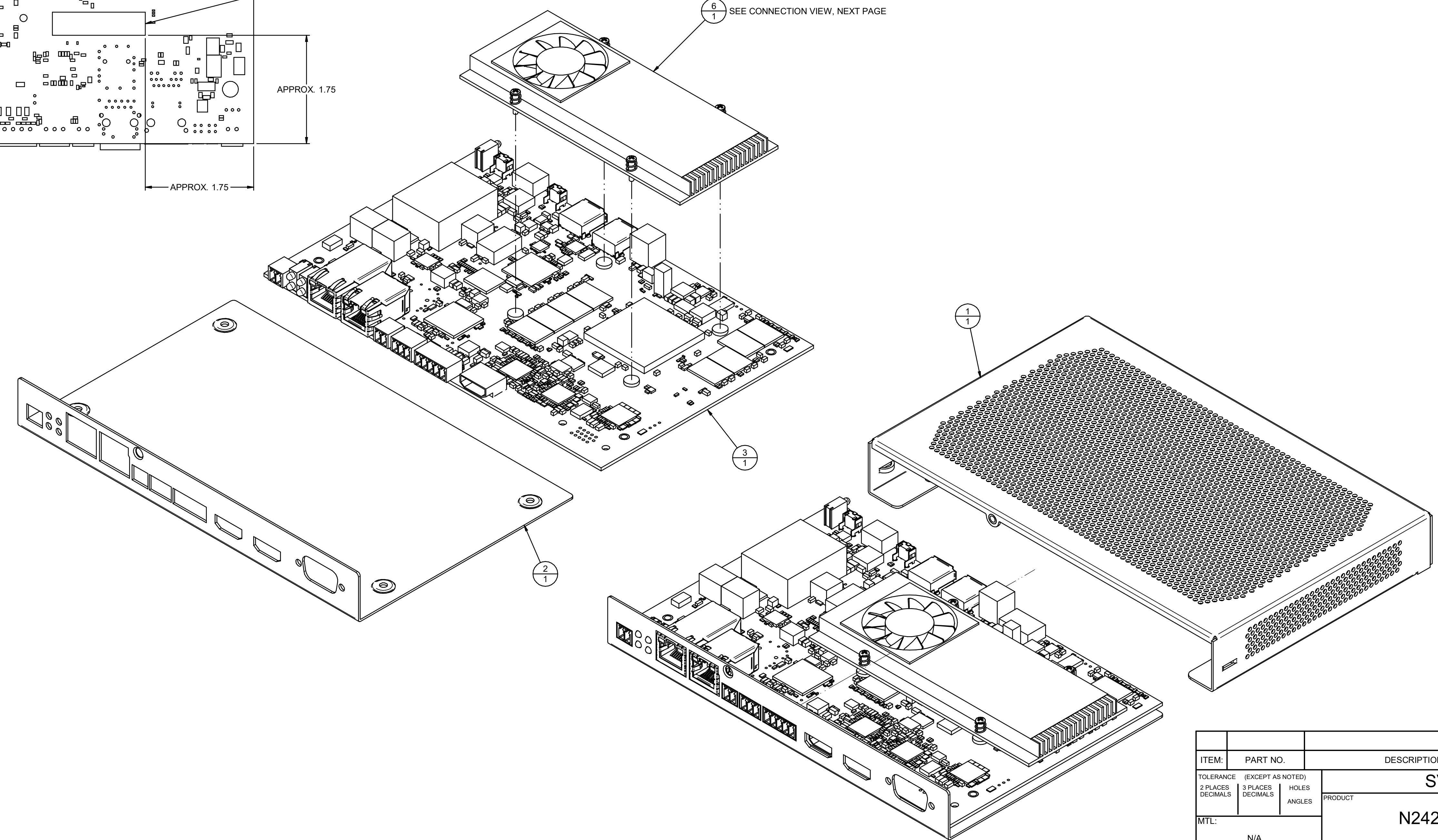
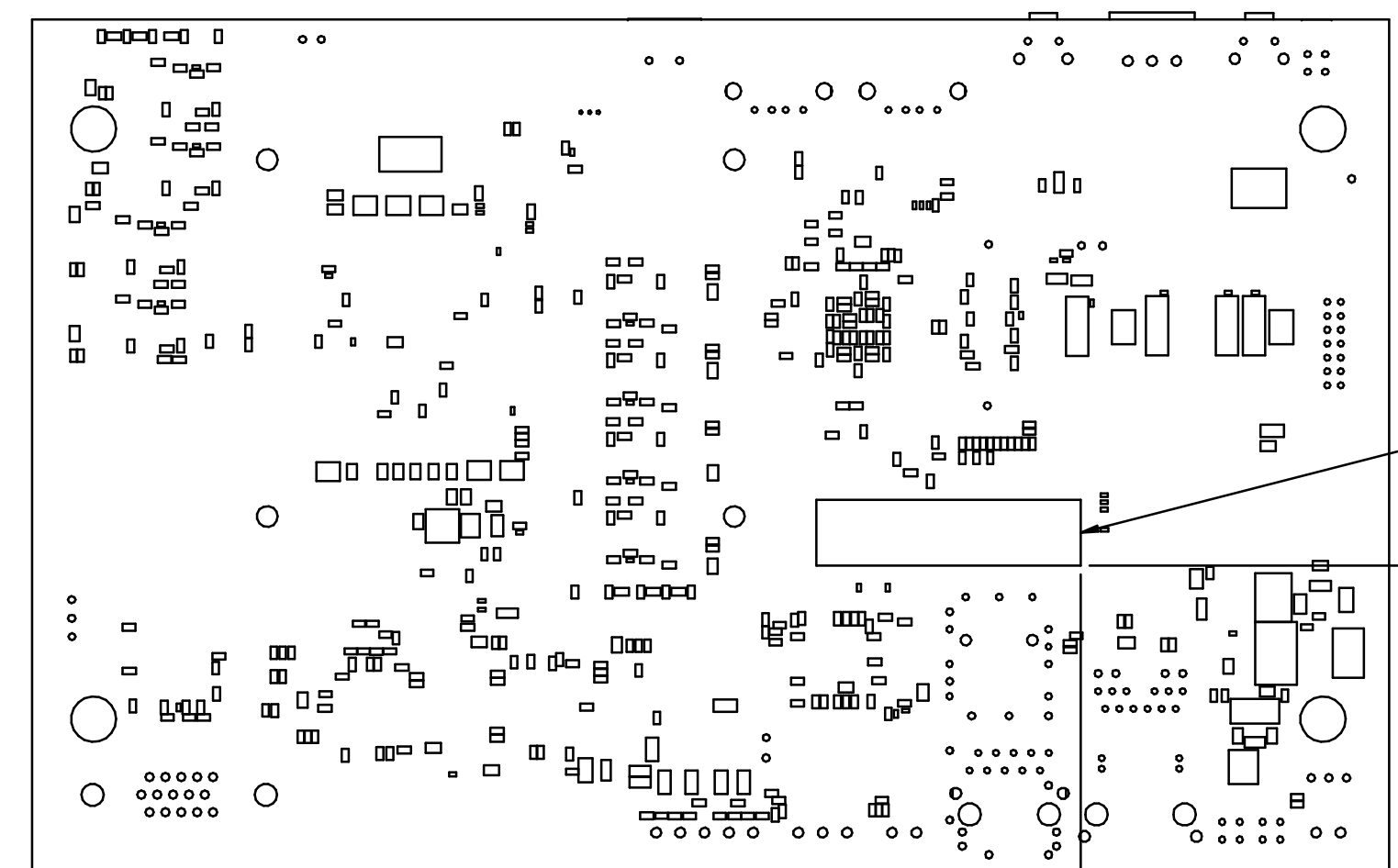

ITEM	PART NO.	DESCRIPTION
TOLERANCE (EXCEPT AS NOTED)		SVSI
2 PLACES DECIMALS	3 PLACES DECIMALS	
HOLES		PRODUCT
ANGLES		
MTL:		N2424A-SA
N/A		DRN END
FINISH:		ENG G. WIRTH
N/A		TITLE:
NEXT ASSY		DWG,ASY,FGN2424A-SA
SCALE	SIZE	DWG NO.
NTS	D	5092084-00
		SHEET 2 OF 4
		FILE NO. TSK1410

REVISION HISTORY			
DATE	REV	ECO #	COMMENT
01/30/18	@B	N/A	REVISED OVERLAY P/N

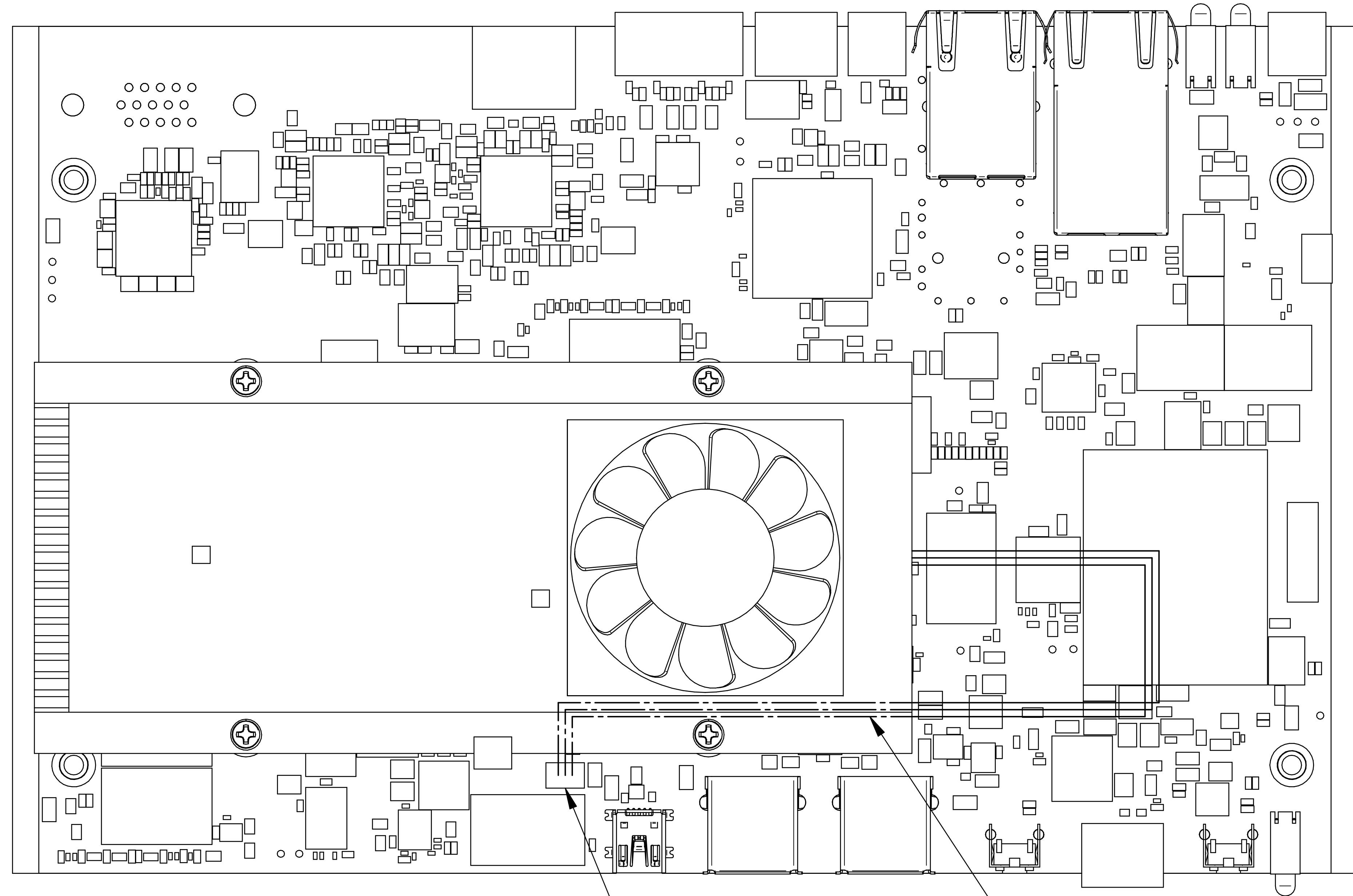

CONNECT TO J14

ROUTE WIRES BEHIND THE HEATSINK MOUNTING SCREW AS SHOWN

ITEM	PART NO.	DESCRIPTION
TOLERANCE 2 PLACES DECIMALS	(EXCEPT AS NOTED) 3 PLACES DECIMALS	HOLES ANGLES
MTL:		PRODUCT
N/A		N2424A-SA
FINISH:		DRN
N/A		END
NEXT ASSY		ENG G. WIRTH
SCALE		TITLE
NTS	D	DWG,ASY,FGN2424A-SA
SIZE		DWG NO.
D		5092084-00
FILE NO.		SHEET 3 OF 4
TSK1410		

REVISION HISTORY			
DATE	REV	ECO #	COMMENT
01/30/18	@B	N/A	REVISED OVERLAY P/N

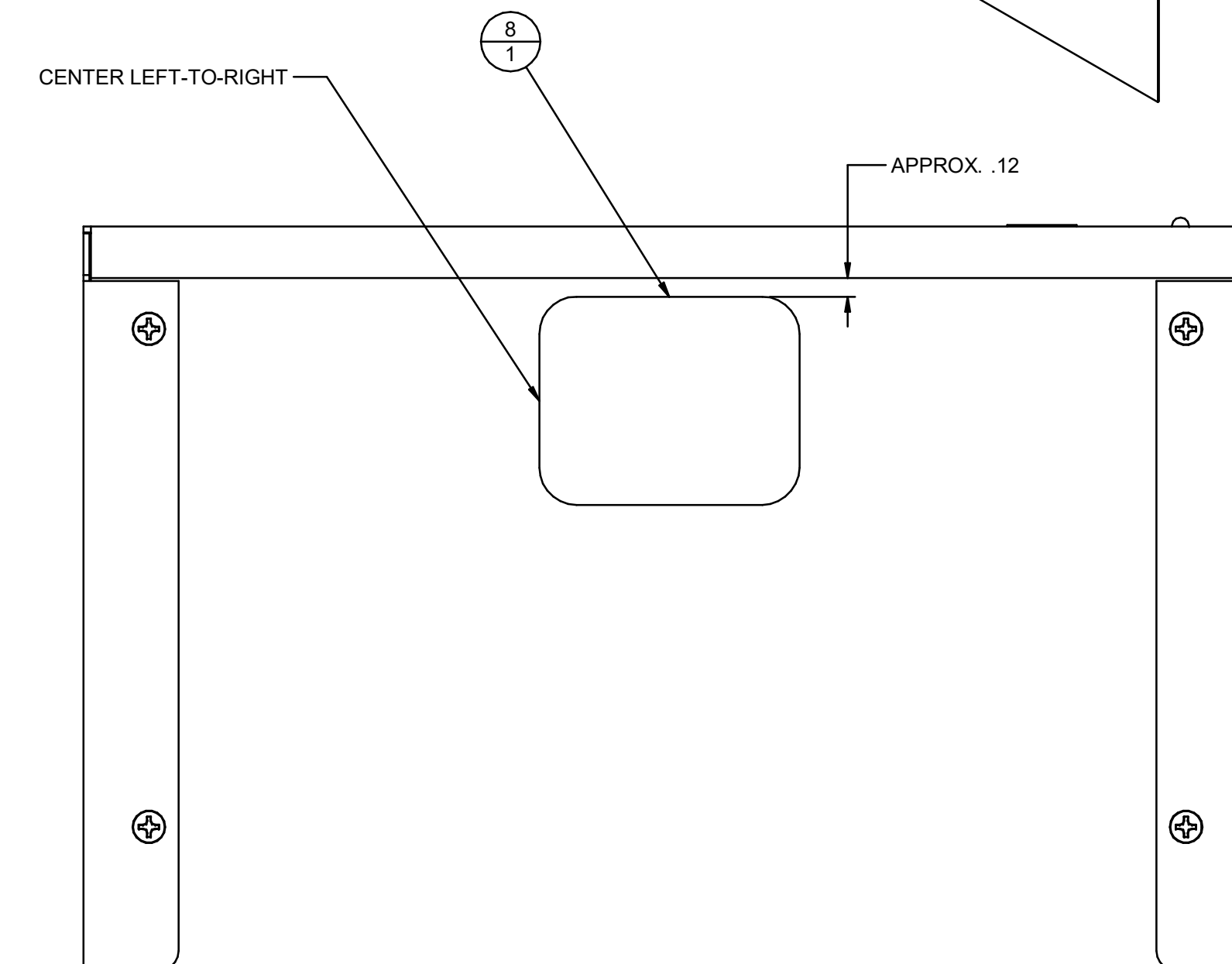
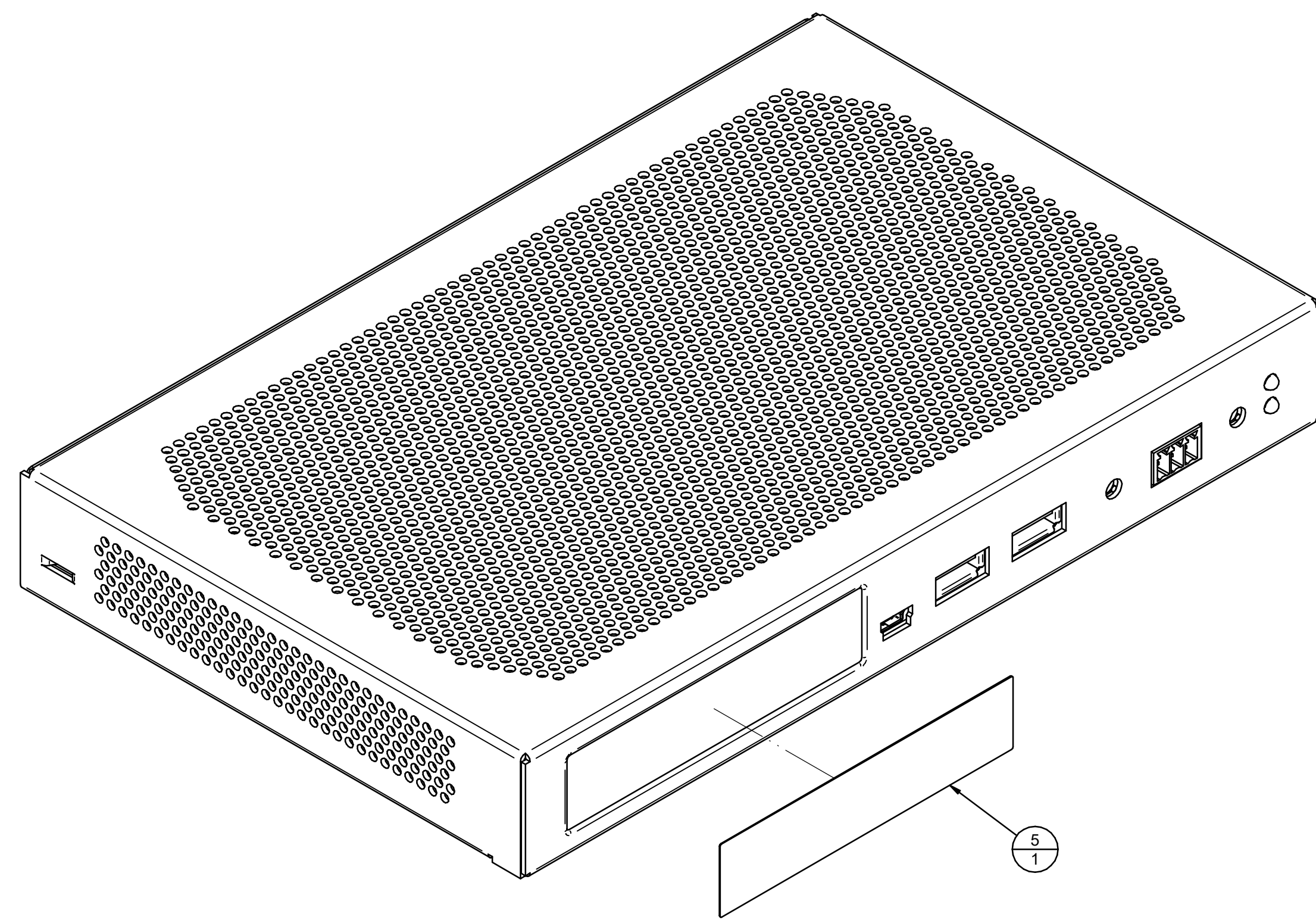
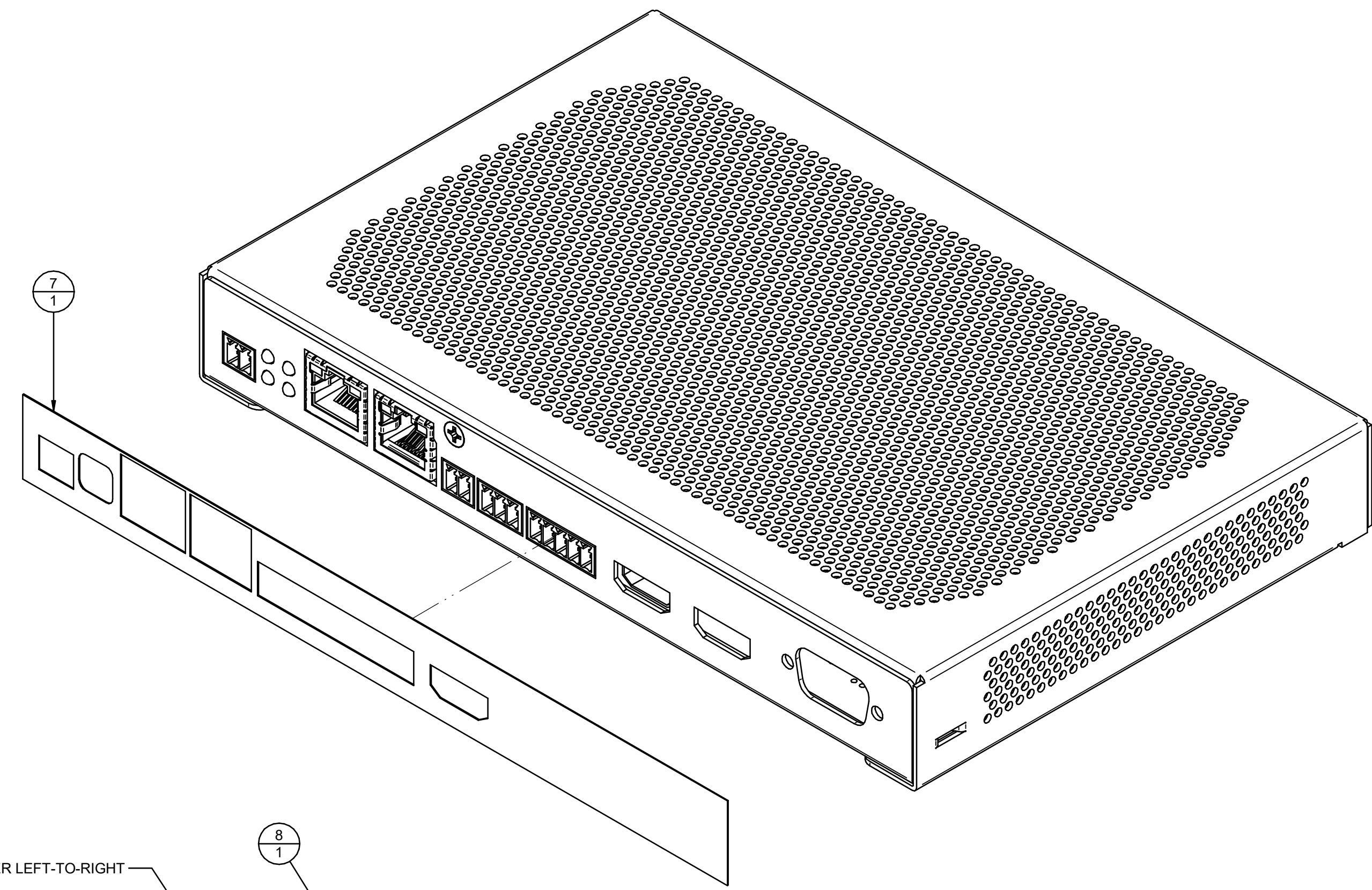
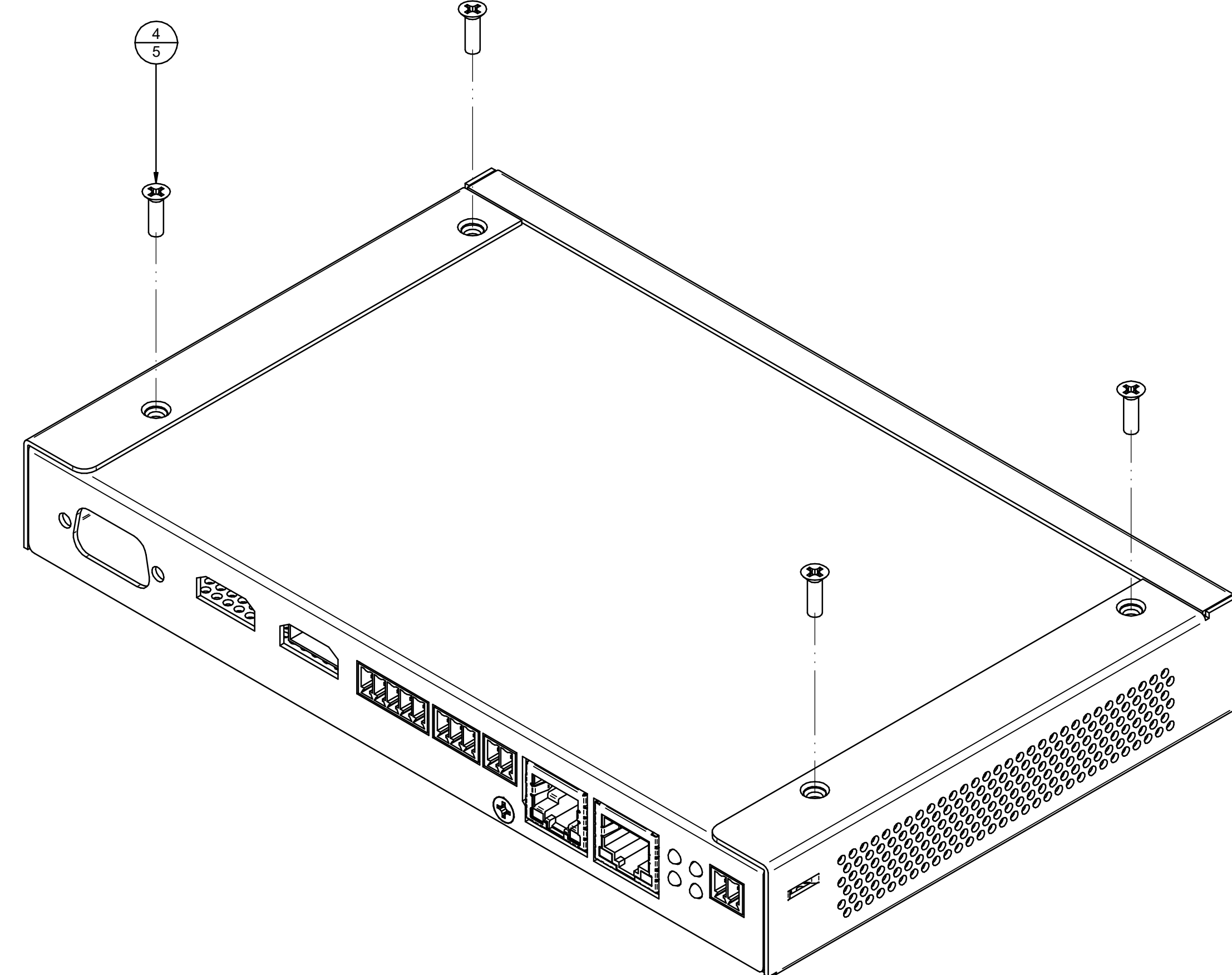

ITEM	PART NO.	DESCRIPTION
TOLERANCE (EXCEPT AS NOTED)		SVSI
2 PLACES DECIMALS	3 PLACES DECIMALS	
HOLES		PRODUCT
ANGLES		N2424A-SA
MTL:		DRN
N/A		END
FINISH:		ENG G. WIRTH
N/A		CHK
NEXT ASSY		ENG
TITLE:		DWG,ASY,FGN2424A-SA
SCALE	SIZE	DWG NO.
NTS	D	5092084-00
SHEET 4 OF 4		FILE NO.
TSK1410		